

Positive Probe Lock System

The design of the probe and probe plate allows for the probe locking plate to positively pin the probe from any possible movement after final assembly. Due to differences of wing designs and the number of wing mounting locations, it may become necessary to change the AOA probe angle to allow for full scale and accurate electronic calibration. Depending on the probe lock plate pin and which side of the AOA probe and hole is used, a range of probe angles can be locked from 35 to 90 degrees, (see drawings at the left). Start with a 50 degree angle, if a higher or lower angle is required, material from the probe plate may have to be removed for clearance of the probe to swing in the desired direction. Once the AOA probe locking plate and the 1/4 bolt is tightened to 60 inch lbs., the probe is pinned in place.

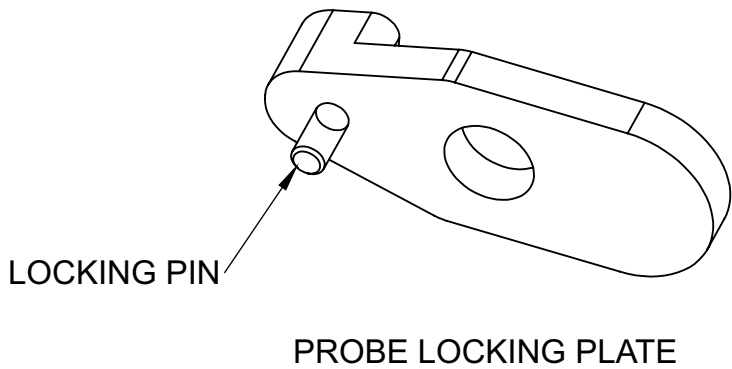
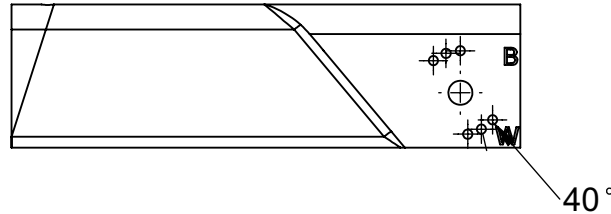
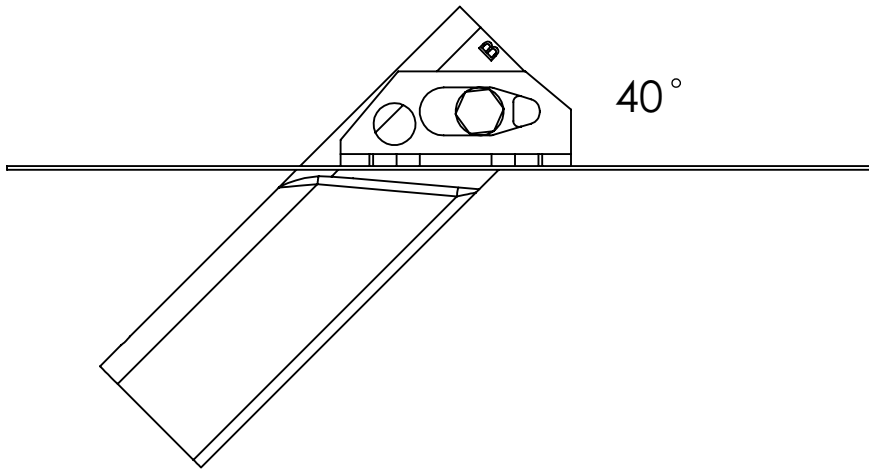

G3 - G5 WING

PATENT PENDING

UNLESS SPECIFIED,
UNITS ARE IN INCHES
AND TOLERANCES ARE:
DIMENSIONS ARE IN INCHES
.X = ±.03
.XX = ±.01
.XXX = ±.005
DEG = ±1°
X/X = ±1/16

THE INFORMATION CONTAINED IN
THIS DRAWING IS THE SOLE PROPERTY
OF DEPOTSTAR
IN PART OR AS A WHOLE WITHOUT THE
WRITTEN PERMISSION OF DEPOTSTAR
IS PROHIBITED.

BRDD : X	
DRAWN AARON	
DATE 9/14/16	PROJECT: PROBE MOUNTING PLATE
SHEET: 1 OF 2	DESCRIPTION: MOUNTING ANGLES
SCALE: NONE	
SIZE: B	
FINISH: *	PART #: PROBE MOUNTING INCREMENTS A
MATERIAL: *	