

Wire Reinforced Synthetic Rubber Hose Assemblies

- Lightweight and Flexible
- Qualified to Industry Standards
- Integral Abrasion and Fire Resistance Covers Available



Aeroquip Wire Reinforced Synthetic Rubber Hose

601/AE701 Hose

Construction: Synthetic rubber inner tube with two layers of stainless steel wire braid reinforcement.

Application: Fuel, engine oil, and coolants.

Basic Specification: MIL-H-83797, TSO C53a, Type A.

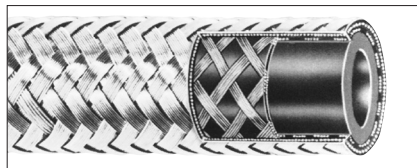

AE501 Hose

Construction: 601/AE701 hose overlaid with a blue braided chafeguard cover of tough polyester yarn.

Application: Fuel, engine oil, and coolants.

Basic Specification: MIL-H-83797, TSO C53a, Type A.

Integral Abrasion Resistant Cover



AE401 Hose

Construction: 601/AE701 hose with an integral cover of silicone rubber compound.

Application: Fuel, engine oil, and coolants.

Basic Specification: MIL-H-83797, TSO C53a, Type C.

Integral Fire Sleeve



Design Features

- Flexibility
- Lightweight
- Fluid temperatures: -65°F to +300°F (-54°C to +149°C)
- TSO C53a, Type A and Type C approvals (with fire sleeve)
- Mil-Spec Approvals:
 - MIL-H-83796/1 through MIL-H-83796/9 Assemblies
 - MIL-H-83797 Hose, MIL-F-83798 Fittings
- Available in sizes -3 thru -32
- Available with polyester/integral sleeve
- Field attachable fittings

NOTE: Hose not intended for vacuum application use. See Mil-H-83797. Hoses that may see intermittent vacuum pressure require an internal support coil. Contact Eaton for additional information.

End Fitting

| | |
|------------------------|---------------------------|
| Nut: -3, -4 and -5 | steel, AMS 5024 (C1137) |
| Nut: -6 and up | aluminum, AMS 4119 (2024) |
| Nut Wire: Cres., | AMS5685 (305) |
| Nipple: -3, -4 and -5 | steel AMS 5024 (C1137) |
| Nipple: -6 and up | aluminum, AMS4119 (2024) |
| Elbow: -3, -4 and -5 | steel AMS5024 |
| (C1137); -6 and up | aluminum, AMS4117 (6061) |
| Socket: AMS4117 (6061) | All sizes |

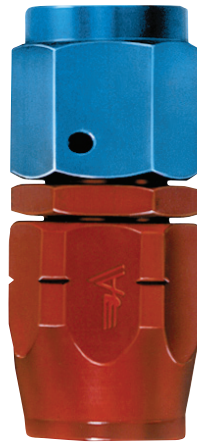

Thread

| Size | Thread |
|------|------------------|
| -3 | .375-24 UNJF-3B |
| -4 | .4375-20 UNJF-3B |
| -5 | .500-20 UNJF-3B |
| -6 | .5625-18 UNJF-3B |
| -8 | .750-16 UNJF-3B |
| -10 | .875-14 UNJF-3B |
| -12 | 1.0625-12 UNJ-3B |
| -16 | 1.3125-12 UNJ-3B |
| -20 | 1.625-12 UNJ-3B |
| -24 | 1.875-12 UNJ-3B |
| -32 | 2.500-12 UNJ-3B |

Hose Dimensions and Performance Data

| Hose Size | -3 | -4 | -5 | -6 | -8 | -10 | -12 | -16 | -20 | -24 | -32 |
|------------------------------|------|------|------|------|------|-------|-------|-------|-------|-------|-------|
| 601/AE701 Hose O.D. (Max.) | .398 | .462 | .508 | .571 | .673 | .820 | .961 | 1.187 | 1.468 | 1.734 | 2.140 |
| AE501 Hose O.D. (Max.) | .470 | .530 | .575 | .659 | .761 | .895 | 1.053 | 1.265 | 1.526 | 1.800 | 2.160 |
| AE401 Hose O.D. (Max.) | .721 | .755 | .801 | .864 | .966 | 1.112 | 1.253 | 1.465 | 1.726 | 2.019 | 2.436 |
| Hose I.D. (Min.) | .141 | .204 | .266 | .329 | .415 | .539 | .665 | .844 | 1.094 | 1.344 | 1.750 |
| Minimum Bend Radius (inches) | 1.75 | 2.00 | 2.25 | 2.50 | 3.50 | 4.00 | 4.50 | 5.50 | 8.00 | 9.00 | 12.50 |
| Operating Pressure (PSI) | 1500 | 1500 | 1500 | 1500 | 1250 | 1250 | 1250 | 1000 | 800 | 400 | 350 |
| Proof Pressure (PSI)3000 | 3000 | 3000 | 3000 | 2500 | 2500 | 2000 | 1500 | 1500 | 1300 | 800 | 600 |
| Minimum Burst Pressure (PSI) | 6000 | 6000 | 6000 | 6000 | 5000 | 5000 | 4000 | 3000 | 2000 | 2000 | 1200 |
| 601/AE701 Hose Wt. (Lb./Ft.) | .093 | .114 | .145 | .155 | .170 | .207 | .285 | .380 | .490 | .675 | .903 |
| AE501 Hose Wt. (Lb./Ft.) | .122 | .138 | .172 | .184 | .204 | .248 | .333 | .439 | .636 | .920 | 1.138 |
| AE401 Hose Wt. (Lb./Ft.) | .257 | .310 | .348 | .351 | .396 | .474 | .592 | .750 | .891 | 1.229 | 1.471 |

All dimensions in inches

Assembly Length

Assembly length is measured from sealing surface to sealing surface. When defining the part number length, measure the length from end point to end point on flareless fittings. With elbow fittings, the measuring point is the intersection of the centerline of the elbow with the face of the sealing surface.

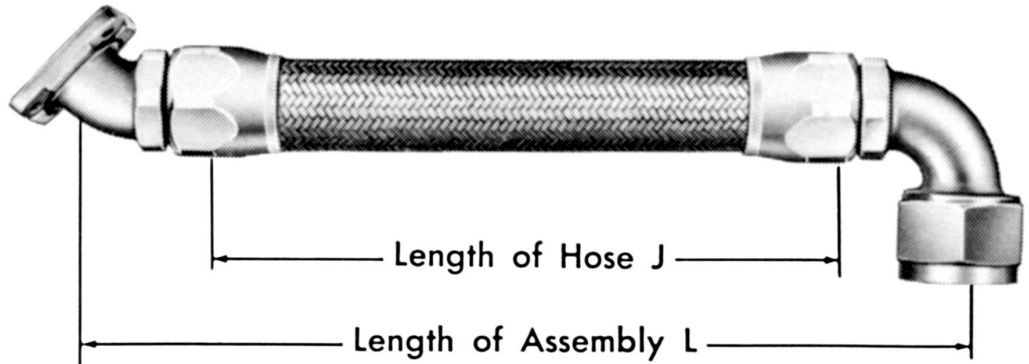

Rotation Angle Measurement

On assemblies with an elbow fitting on each end, measure the rotation angle as shown. The index angle will follow the basic style hose assembly part number indicated (see example for "double elbow" assemblies). In all cases, the angle should be expressed in 3 digits. For example, 35° should be written as 035. If the angle desired is 0°, specify 000.

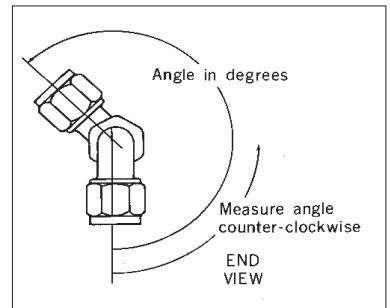

Assembly Length Tolerances

| | |
|--|-------|
| Up to and including 8 inches: | ±.125 |
| Above 8 inches, to and including 16 inches: | ±.187 |
| Above 16 inches, to and including 24 inches: | ±.250 |
| Above 24 inches, to and including 36 inches: | ±.312 |
| Above 36 inches, or longer: | ±1% |

Hose Assemblies

To properly specify the correct hose assembly, use the simple numbering system below. Straight and single elbow assemblies are identified by the number beginning with AE701 and double elbow assemblies are identified by a number beginning with AE70XX. Any assembly can be ordered using these numbers.

Bulk Hose

Bulk hose will be supplied in 25-foot lengths whenever possible, but the right is reserved to ship random lengths over 3 feet unless otherwise specified. Contact your Eaton representative if you have questions. An additional charge will be made for hose cut to specified lengths.

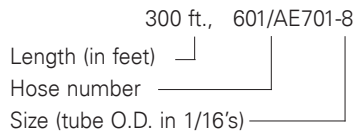

Examples

Straight and Single Elbow Hose Assemblies

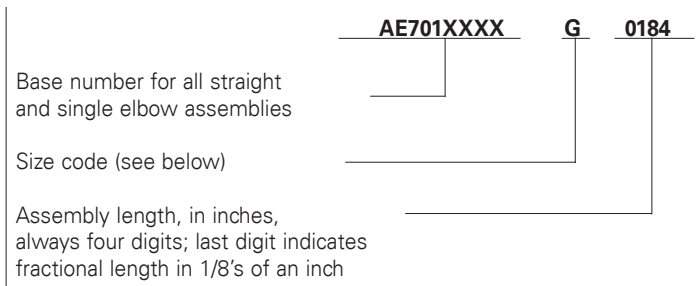

| | | | | | | | | | | | |
|----------------|---|---|---|---|---|----|----|----|----|----|----|
| Hose Dash Size | 3 | 4 | 5 | 6 | 8 | 10 | 12 | 16 | 20 | 24 | 32 |
| Letter Code | B | E | F | G | H | J | K | M | N | P | R |

Double Elbow Hose Assemblies

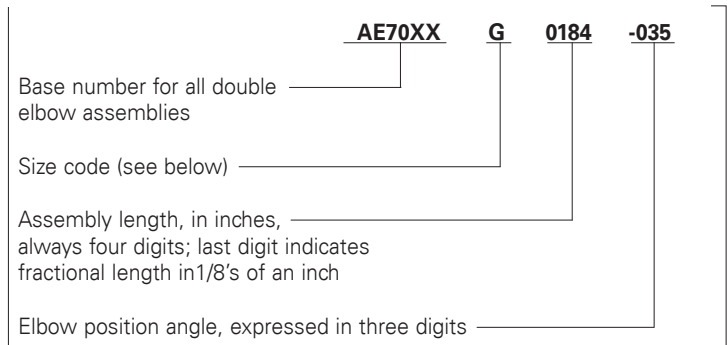

Flared Fitting

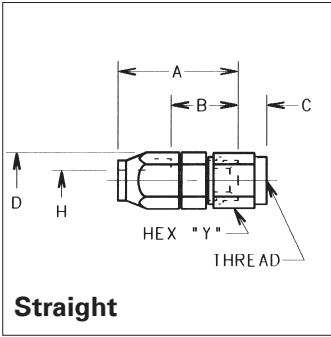

Straight

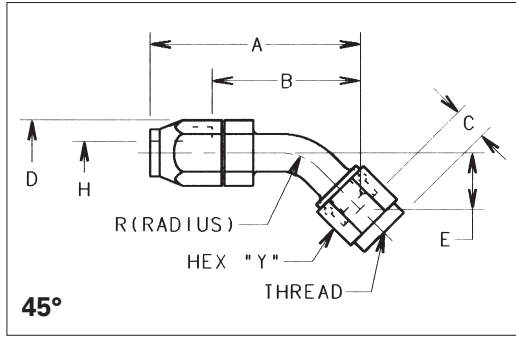

45°

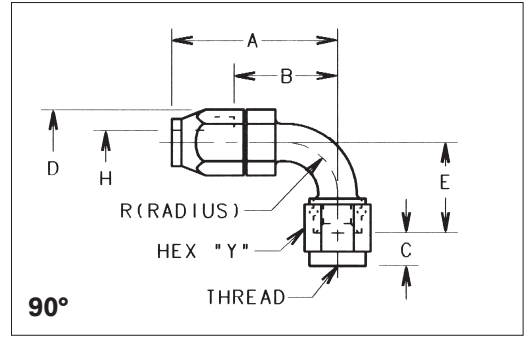

90°

Straight Fitting Dimensions (M83798/1-Size)

| Hose Size | Fitting P/N | Nipple P/N | Max. Dim. A | Dim. B | Dim. C | Max. Dim. D | Dim. R* | Dim. H | Nut Hex*** | Socket Hex*** | Fitting Wt.** | Dim. E |
|-----------|-------------|------------|-------------|--------|--------|-------------|---------|--------|------------|---------------|---------------|--------|
| -3 | 816-3 | 526-3 | 1.30 | .64 | .34 | .64 | — | .103 | .58 | .562 | .049 | — |
| -4 | 816-4 | 526-4 | 1.33 | .65 | .37 | .70 | — | .150 | .65 | .625 | .061 | — |
| -5 | 816-5 | 526-5 | 1.38 | .70 | .38 | .76 | — | .211 | .72 | .688 | .078 | — |
| -6 | 816-6D | 526-6D | 1.51 | .76 | .38 | .83 | — | .274 | .80 | .750 | .046 | — |
| -8 | 816-8D | 526-8D | 1.79 | .94 | .43 | 1.04 | — | .366 | 1.01 | .875 | .078 | — |
| -10 | 816-10D | 526-10D | 1.94 | .99 | .50 | 1.18 | — | .472 | 1.16 | 1.062 | .108 | — |
| -12 | 816-12D | 526-12D | 2.01 | 1.00 | .57 | 1.47 | — | .576 | 1.45 | 1.188 | .168 | — |
| -16 | 816-16D | 526-16D | 2.36 | 1.16 | .60 | 1.76 | — | .781 | 1.74 | 1.438 | .240 | — |
| -20 | 816-20D | 526-20D | 2.64 | 1.34 | .64 | 2.11 | — | 1.026 | 2.11 | 1.750 | .372 | — |
| -24 | 816-24D | 526-24D | 2.79 | 1.44 | .74 | 2.47 | — | 1.264 | 2.48 | 1.938 | .504 | — |
| -32 | 816-32D | 526-32D | 3.16 | 1.62 | .92 | 3.20 | — | 1.684 | 3.20 | 2.500 | .900 | — |

45° Fitting Dimensions (M83798/2-Size)

| | | | | | | | | | | | | |
|-----|----------|----------|------|------|-----|------|-------|-------|------|-------|------|-------|
| -3 | 8846-3 | 8746-3 | 1.74 | 1.05 | .34 | .64 | .375 | .103 | .58 | .562 | .056 | .376 |
| -4 | 8846-4 | 8746-4 | 1.72 | 1.02 | .37 | .70 | .375 | .150 | .65 | .625 | .070 | .352 |
| -5 | 8846-5 | 8746-5 | 1.83 | 1.12 | .38 | .76 | .438 | .211 | .72 | .688 | .091 | .415 |
| -6 | 8846-6D | 8746-6D | 2.00 | 1.22 | .38 | .83 | .500 | .274 | .80 | .750 | .052 | .446 |
| -8 | 8846-8D | 8746-8D | 2.17 | 1.30 | .43 | .98 | .500 | .366 | 1.01 | .875 | .085 | .457 |
| -10 | 8846-10D | 8746-10D | 2.42 | 1.44 | .50 | 1.17 | .625 | .472 | 1.16 | 1.062 | .119 | .537 |
| -12 | 8846-12D | 8746-12D | 2.79 | 1.76 | .57 | 1.30 | .844 | .576 | 1.45 | 1.188 | .179 | .623 |
| -16 | 8846-16D | 8746-16D | 3.06 | 1.83 | .60 | 1.55 | .969 | .781 | 1.74 | 1.438 | .255 | .659 |
| -20 | 8846-20D | 8746-20D | 3.45 | 2.13 | .64 | 1.91 | 1.188 | 1.026 | 2.11 | 1.750 | .376 | .768 |
| -24 | 8846-24D | 8746-24D | 3.65 | 2.28 | .74 | 2.11 | 1.375 | 1.264 | 2.48 | 1.938 | .506 | .867 |
| -32 | 8846-32D | 8746-32D | 4.26 | 2.69 | .92 | 2.72 | 1.750 | 1.684 | 3.20 | 2.500 | .891 | 1.065 |

90° Fitting Dimensions (M83798/3-Size)

| | | | | | | | | | | | | |
|-----|----------|----------|------|------|-----|------|-------|-------|------|-------|------|-------|
| -3 | 8891-3 | 8791-3 | 1.58 | .89 | .34 | .64 | .375 | .103 | .58 | .562 | .057 | .752 |
| -4 | 8891-4 | 8791-4 | 1.59 | .89 | .37 | .70 | .375 | .150 | .65 | .625 | .071 | .718 |
| -5 | 8891-5 | 8791-5 | 1.68 | .96 | .38 | .76 | .438 | .211 | .72 | .688 | .094 | .844 |
| -6 | 8891-6D | 8791-6D | 1.85 | 1.07 | .38 | .83 | .500 | .274 | .80 | .750 | .053 | .922 |
| -8 | 8891-8D | 8791-8D | 2.01 | 1.14 | .43 | .98 | .500 | .366 | 1.01 | .875 | .088 | .938 |
| -10 | 8891-10D | 8791-10D | 2.25 | 1.27 | .50 | 1.17 | .625 | .472 | 1.16 | 1.062 | .124 | 1.126 |
| -12 | 8891-12D | 8791-12D | 2.66 | 1.63 | .57 | 1.30 | .844 | .576 | 1.45 | 1.188 | .189 | 1.376 |
| -16 | 8891-16D | 8791-16D | 2.97 | 1.74 | .60 | 1.55 | .969 | .781 | 1.74 | 1.438 | .267 | 1.500 |
| -20 | 8891-20D | 8791-20D | 3.38 | 2.06 | .64 | 1.91 | 1.188 | 1.026 | 2.11 | 1.750 | .399 | 1.782 |
| -24 | 8891-24D | 8791-24D | 3.59 | 2.22 | .74 | 2.11 | 1.375 | 1.264 | 2.48 | 1.938 | .538 | 2.032 |
| -32 | 8891-32D | 8791-32D | 4.22 | 2.65 | .92 | 2.72 | 1.750 | 1.684 | 3.20 | 2.500 | .953 | 2.532 |

All dimensions in inches

DIM. B = Hose cut factor.

DIM. E = Nominal drop dimensions. Tolerance is ±.035" on bent tube fittings.



*R = Radius of elbow measured to centerline.

**Weight = Nipple assembly plus socket (nominal).

*** = Distance across corners.

Socket P/N 516-XXD

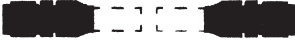
Hose Assembly/Swivel Flared to Swivel Flared

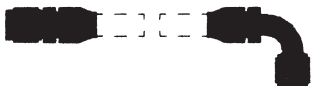
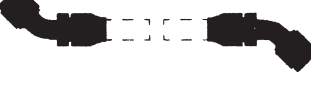
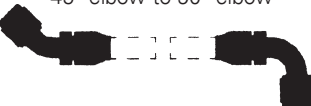
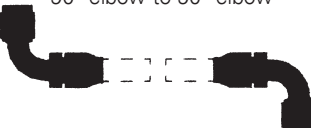
| Configurations | Hose Size | 601/AE701 Hose Assembly Base No. | AE501 Hose Assembly Base No. | AE401 Hose Assembly Base No. | 601/AE701 W/AE102 Firesleeves Hose Assembly Base No. |
|---|------------|---|---------------------------------------|---------------------------------------|--|
| <p>straight to straight</p>  | -3 thru-32 | AE7010000 | AE7013110 | AE7013106 | AE7010001 |
| <p>straight to 45° elbow</p>  | -3 thru-32 | AE7010100 | AE7013111 | AE7013107 | AE7010101 |
| <p>straight to 90° elbow</p>  | -3 thru-32 | AE7010200 | AE7013112 | AE7013131 | AE7010201 |
| <p>45° elbow to 45° elbow</p>  | -3 thru-32 | AE7000 | AE7058 | AE7074 | AE7001 |
| <p>45° elbow to 90° elbow</p>  | -3 thru-32 | AE7012 | AE7059 | AE7075 | AE7013 |
| <p>90° elbow to 90° elbow</p>  | -3 thru-32 | AE7027 | AE7060 | AE7076 | AE7028 |

Flareless Fitting

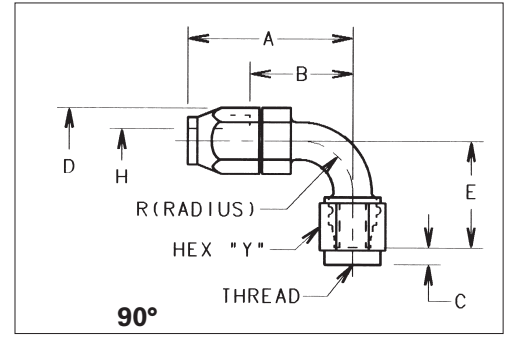
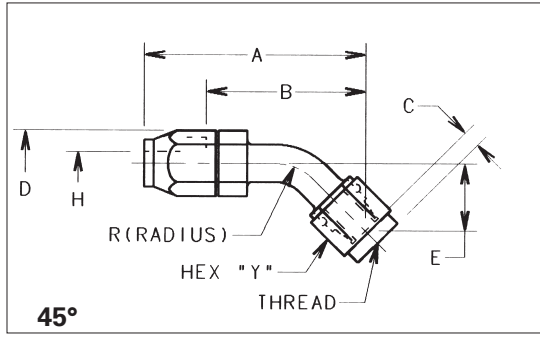
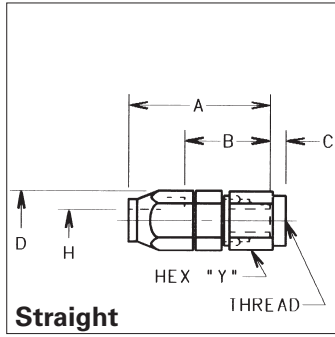

Straight Fitting Dimensions (M83798/4-Size)

| Hose Size | Fitting P/N | Nipple P/N | Dim. A | Dim. B | Dim. C | Dim. D | Dim. R* | Dim. H | Nut Hex*** | Socket Hex*** | Fitting Wt.** | Dim. E |
|-----------|-------------|------------|--------|--------|--------|--------|---------|--------|------------|---------------|---------------|--------|
| -3 | 826-3 | 536-3 | 1.52 | .85 | .13 | .64 | — | .103 | .58 | .640 | .051 | — |
| -4 | 826-4 | 536-4 | 1.48 | .80 | .22 | .70 | — | .150 | .654 | .703 | .064 | — |
| -5 | 826-5 | 536-5 | 1.54 | .86 | .23 | .76 | — | .211 | .72 | .765 | .080 | — |
| -6 | 826-6D | 536-6D | 1.71 | .96 | .19 | .83 | — | .274 | .798 | .827 | .048 | — |
| -8 | 826-8D | 536-8D | 2.02 | 1.17 | .21 | 1.04 | — | .366 | 1.014 | .984 | .082 | — |
| -10 | 826-10D | 536-10D | 2.22 | 1.26 | .24 | 1.18 | — | .472 | 1.158 | 1.171 | .115 | — |
| -12 | 826-12D | 536-12D | 2.28 | 1.27 | .31 | 1.47 | — | .576 | 1.447 | 1.296 | .175 | — |
| -16 | 826-16D | 536-16D | 2.64 | 1.44 | .32 | 1.76 | — | .781 | 1.736 | 1.546 | .254 | — |
| -20 | 826-20D | 536-20D | 2.92 | 1.62 | .37 | 2.11 | — | 1.026 | 2.111 | 1.906 | .368 | — |
| -24 | 826-24D | 536-24D | 3.19 | 1.85 | .33 | 2.47 | — | 1.264 | 2.477 | 2.109 | .544 | — |
| -32 | — | — | — | — | — | — | — | — | — | — | — | — |

45° Fitting Dimensions (M83798/5-Size)

| Hose Size | Fitting P/N | Nipple P/N | Dim. A | Dim. B | Dim. C | Dim. D | Dim. R* | Dim. H | Nut Hex*** | Socket Hex*** | Fitting Wt.** | Dim. E |
|-----------|-------------|------------|--------|--------|--------|--------|---------|--------|------------|---------------|---------------|--------|
| -3 | — | — | — | — | — | — | — | — | — | — | — | — |
| -4 | 880112-4 | 885112-4 | 1.72 | 1.1 | .22 | .70 | .25 | .150 | .654 | .703 | .070 | .452 |
| -5 | — | — | — | — | — | — | — | — | — | — | — | — |
| -6 | 880112-6D | 885112-6D | 2.03 | 1.36 | .19 | .83 | .50 | .274 | .798 | .827 | .054 | .578 |
| -8 | 880112-8D | 885112-8D | 2.32 | 1.45 | .21 | .98 | .50 | .366 | 1.014 | .984 | .088 | .610 |
| -10 | 880112-10D | 885112-10D | 2.61 | 1.63 | .24 | 1.17 | .62 | .472 | 1.158 | 1.171 | .125 | .725 |
| -12 | 880112-12D | 885112-12D | 2.97 | 1.93 | .31 | 1.30 | .84 | .576 | 1.447 | 1.296 | .189 | .800 |
| -16 | 880112-16D | 885112-16D | 3.25 | 2.03 | .32 | 1.55 | .97 | .781 | 1.736 | 1.546 | .270 | .854 |
| -20 | 880112-20D | 885112-20D | 3.65 | 2.33 | .37 | 1.91 | 1.19 | 1.026 | 2.111 | 1.906 | .408 | .962 |
| -24 | — | — | — | — | — | — | — | — | — | — | — | — |
| -32 | — | — | — | — | — | — | — | — | — | — | — | — |

90° Fitting Dimensions (M83798/6-Size)

| Hose Size | Fitting P/N | Nipple P/N | Dim. A | Dim. B | Dim. C | Dim. D | Dim. R* | Dim. H | Nut Hex*** | Socket Hex*** | Fitting Wt.** | Dim. E |
|-----------|-------------|------------|--------|--------|--------|--------|---------|--------|------------|---------------|---------------|--------|
| -3 | — | — | — | — | — | — | — | — | — | — | — | — |
| -4 | 880114-4 | 885114-4 | 1.59 | .89 | .22 | .70 | .25 | .150 | .654 | .703 | .070 | .860 |
| -5 | 880114-5 | 885114-5 | 1.68 | .96 | .23 | .76 | .31 | .211 | .720 | .765 | .071 | 1.000 |
| -6 | 880114-6D | 885114-6D | 1.85 | 1.07 | .19 | .83 | .50 | .274 | .798 | .827 | .057 | 1.112 |
| -8 | 880114-8D | 885114-8D | 2.01 | 1.14 | .21 | .98 | .50 | .366 | 1.014 | .984 | .092 | 1.156 |
| -10 | 880114-10D | 885114-10D | 2.25 | 1.27 | .24 | 1.17 | .62 | .472 | 1.158 | 1.171 | .130 | 1.392 |
| -12 | 880114-12D | 885114-12D | 2.66 | 1.63 | .31 | 1.30 | .84 | .576 | 1.447 | 1.296 | .199 | 1.626 |
| -16 | 880114-16D | 885114-16D | 2.97 | 1.74 | .32 | 1.55 | .97 | .781 | 1.736 | 1.546 | .282 | 1.776 |
| -20 | 880114-20D | 885114-20D | 3.38 | 2.06 | .37 | 1.91 | 1.19 | 1.026 | 2.111 | 1.906 | .431 | 2.056 |
| -24 | — | — | — | — | — | — | — | — | — | — | — | — |
| -32 | — | — | — | — | — | — | — | — | — | — | — | — |

All dimensions in inches

DIM. B = Hose cut factor.

DIM. E = Nominal drop dimensions. Tolerance is ±.035" on bent tube fittings.

*R = Radius of elbow measured to centerline.

**Weight = Nipple assembly plus socket (nominal).

*** = Distance across corners.

Socket P/N 516-XXD

Hose Assembly/Swivel Flareless to Swivel Flareless

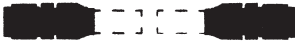
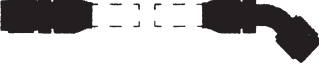
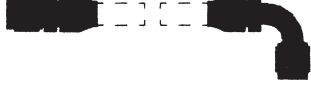
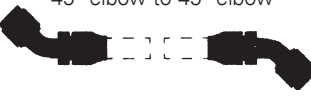
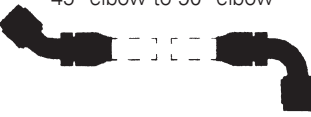
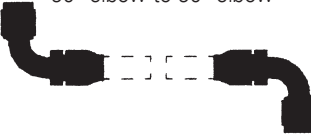
| Configurations | Hose Size | 601/AE701 Hose Assembly Base No. | AE501 Hose Assembly Base No. | AE401 Hose Assembly Base No. | 601/AE701 w/AS1072 Firesleeves Hose Assembly Base No. |
|---|------------|---|---------------------------------------|---------------------------------------|---|
| <p>straight to straight</p>  | -3 thru-32 | AE7010010 | AE7013121 | AE7013132 | AE7010011 |
| <p>straight to 45° elbow</p>  | -3 thru-32 | AE7010110 | AE7013123 | AE7013133 | AE7010111 |
| <p>straight to 90° elbow</p>  | -3 thru-32 | AE7010210 | AE7013125 | AE7013134 | AE7010211 |
| <p>45° elbow to 45° elbow</p>  | -3 thru-32 | AE7003 | AE7066 | AE7077 | AE7004 |
| <p>45° elbow to 90° elbow</p>  | -3 thru-32 | AE7015 | AE7068 | AE7078 | AE7016 |
| <p>90° elbow to 90° elbow</p>  | -3 thru-32 | AE7030 | AE7070 | AE7079 | AE7031 |

Flanged Fitting

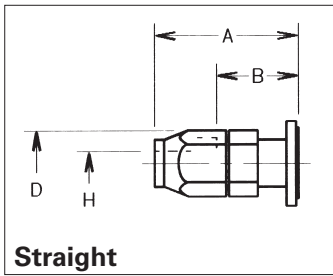

Straight

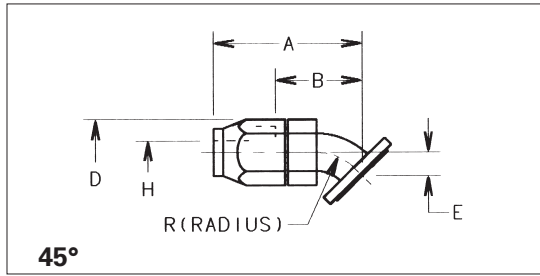

45°

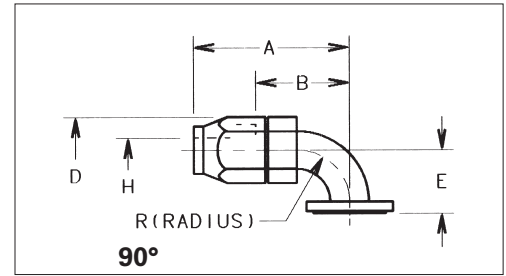

90°

Straight Fitting Dimensions (M83798/7-Size)

| Hose Size | Fitting P/N | Nipple P/N | Max. Dim. A | Dim. B | Dim. C | Max. Dim. D | Dim. R* | Dim. H | Socket Hex*** | Fitting Wt.** | Dim. E |
|-----------|-------------|------------|-------------|--------|--------|-------------|---------|--------|---------------|---------------|--------|
| -3 | — | — | — | — | — | — | — | — | — | — | — |
| -4 | — | — | — | — | — | — | — | — | — | — | — |
| -5 | — | — | — | — | — | — | — | — | — | — | — |
| -6 | — | — | — | — | — | — | — | — | — | — | — |
| -8 | 8844-8D | 8714-8D | 1.97 | .84 | — | .980 | — | .355 | .875 | .089 | — |
| -10 | 8844-10D | 8714-10D | 2.08 | .87 | — | 1.170 | — | .472 | 1.062 | .114 | — |
| -12 | 8844-12D | 8714-12D | 2.29 | 1.25 | — | 1.296 | — | .576 | 1.188 | .153 | — |
| -16 | 8844-16D | 8714-16D | 2.53 | 1.30 | — | 1.546 | — | .781 | 1.438 | .206 | — |
| -20 | 8844-20D | 8714-20D | 2.83 | 1.50 | — | 1.906 | — | 1.026 | 1.750 | .316 | — |
| -24 | 8844-24D | 8714-24D | 2.71 | 1.34 | — | 2.109 | — | 1.264 | 1.938 | .364 | — |
| -32 | 8844-32D | 8714-32D | 3.08 | 1.52 | — | 2.718 | — | 1.684 | 2.500 | .646 | — |

45° Fitting Dimensions (M83798/8-Size)

| | | | | | | | | | | | |
|-----|----------|----------|------|------|---|-------|-------|-------|-------|------|------|
| -3 | — | — | — | — | — | — | — | — | — | — | — |
| -4 | — | — | — | — | — | — | — | — | — | — | — |
| -5 | — | — | — | — | — | — | — | — | — | — | — |
| -6 | — | — | — | — | — | — | — | — | — | — | — |
| -8 | 8845-8D | 8745-8D | .208 | 1.18 | — | .980 | .500 | .360 | .875 | .088 | .338 |
| -10 | 8845-10D | 8745-10D | .226 | 1.28 | — | 1.170 | .625 | .472 | 1.063 | .113 | .375 |
| -12 | 8845-12D | 8745-12D | 2.64 | 1.60 | — | 1.296 | .844 | .576 | 1.188 | .157 | .468 |
| -16 | 8845-16D | 8745-16D | 2.90 | 1.68 | — | 1.546 | .969 | .781 | 1.438 | .208 | .505 |
| -20 | 8845-20D | 8745-20D | 3.25 | 1.93 | — | 1.906 | 1.188 | 1.026 | 1.750 | .321 | .569 |
| -24 | 8845-24D | 8745-24D | 3.40 | 2.03 | — | 2.109 | 1.375 | 1.264 | 1.938 | .386 | .625 |
| -32 | 8845-32D | 8745-32D | 3.92 | 2.36 | — | 2.718 | 1.750 | 1.684 | 2.500 | .672 | .734 |

90° Fitting Dimensions (M83798/9-Size)

| | | | | | | | | | | | |
|-----|----------|----------|------|------|---|-------|-------|-------|-------|-------|-------|
| -3 | — | — | — | — | — | — | — | — | — | — | — |
| -4 | — | — | — | — | — | — | — | — | — | — | — |
| -5 | — | — | — | — | — | — | — | — | — | — | — |
| -6 | — | — | — | — | — | — | — | — | — | — | — |
| -8 | 8890-8D | 8790-8D | 2.35 | 1.48 | — | .980 | .500 | .360 | .875 | .097 | .892 |
| -10 | 8890-10D | 8790-10D | 2.51 | 1.53 | — | 1.170 | .625 | .484 | 1.063 | 1.123 | .896 |
| -12 | 8890-12D | 8790-12D | 2.66 | 1.63 | — | 1.296 | .844 | .576 | 1.188 | .164 | 1.156 |
| -16 | 8890-16D | 8790-16D | 2.97 | 1.74 | — | 1.546 | .969 | .781 | 1.438 | .222 | 1.282 |
| -20 | 8890-20D | 8790-20D | 3.38 | 2.06 | — | 1.906 | 1.188 | 1.026 | 1.750 | .344 | 1.500 |
| -24 | 8890-24D | 8790-24D | 3.54 | 2.22 | — | 2.109 | 1.375 | 1.264 | 1.938 | .448 | 1.688 |
| -32 | 8890-32D | 8790-32D | 4.21 | 2.65 | — | 2.718 | 1.750 | 1.684 | 2.500 | .732 | 2.062 |

All dimensions in inches

DIM. B = Hose cut factor.

DIM. E = Nominal drop dimensions. Tolerance is $\pm .035^{\circ}$ on bent tube fittings.

*R = Radius of elbow measured to centerline.

**Weight = Nipple assembly plus socket (nominal).

*** = Distance across corners.

Socket P/N 516-XXD

| Configurations | Hose Size | 601/AE701 Hose Assembly Base No. | 601/AE701 w/AS1072 Firesleeves Hose Assembly Base No. |
|---|------------|---|---|
| <p>straight to straight</p>  | -8 thru-32 | AE7010020 | AE7010021 |
| <p>straight to 45° elbow</p>  | -8 thru-32 | AE7010120 | AE7010121 |
| <p>straight to 90° elbow</p>  | -8 thru-32 | AE7010220 | AE7010221 |
| <p>45° elbow to 45° elbow</p>  | -8 thru-32 | AE7006 | AE7007 |
| <p>45° elbow to 90° elbow</p>  | -8 thru-32 | AE7018 | AE7019 |
| <p>90° elbow to 90° elbow</p>  | -8 thru-32 | AE7033 | AE7034 |

How to Assemble 601/AE701 Hose Assemblies with "little gem" Straight Fittings and Elbows

To make hose assembly of length "L," cut hose to length "J." Obtain "J" length by subtracting proper fitting allowances. See "B" dimensions on fitting pages.

Straight Fittings

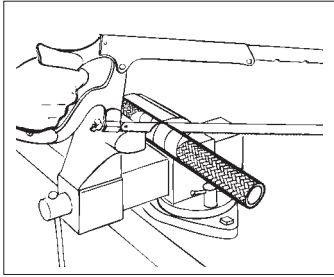

Step 1.
Cut hose squarely to length. Use hose cut-off machine or fine tooth hacksaw. To minimize wire braid flare-out, wrap hose with masking tape and saw through tape. Remove tape before step 2.

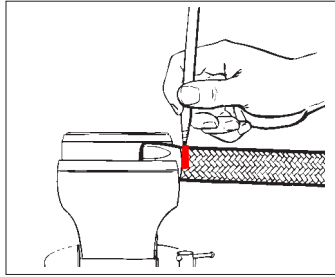

Step 3.
Important – mark hose position around hose at rear of socket. Use a grease pencil, painted line or tape.

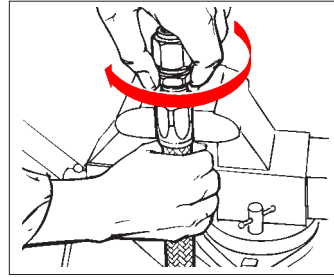

Step 5.
Carefully insert nipple and engage nipple and socket threads while holding hose in position with other hand. Make sure that hose does not push out of socket by observing mark made in step 3.

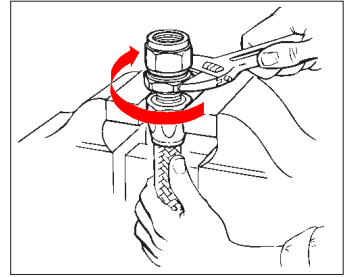

Step 6.
Complete assembly using wrench while continuing to hold in position. Maximum allowable gap is .041 inches in sizes 3, 4 and 5, and .031 inches in size 6 and up.

Step 2.
Insert hose in socket with a twisting, pushing motion until hose is in line with back of socket threads.

Step 4.
Lubricate inside of hose and nipple threads liberally. Use SAE30 lubricating oil. Avoid getting oil in the cutting spur of the nipple.

Step 7.
IMPORTANT – check for hose push-out by observing hose position mark. None should be evident. Clean, inspect and proof test.

Note: Hose push-out after proof test should not exceed 1/32 inch or size 12 and up. None is allowable on smaller sizes.

Elbow Fittings

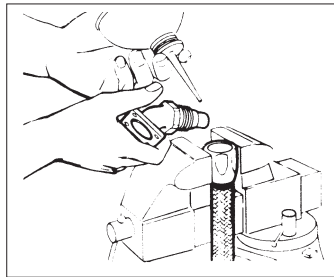

Step 1.
Follow through steps 1, 2, and 3, above.

Step 2.
Flange elbow fittings. Drop flange over threaded end of nipple. Nipple shoulder must fit into counterbore of flange.

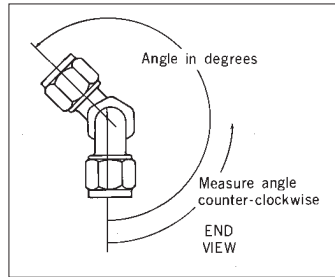

Step 4.
Carefully insert nipple and engage nipple and socket threads while holding hose in position with other hand. Make sure hose does not push out of socket by observing mark.

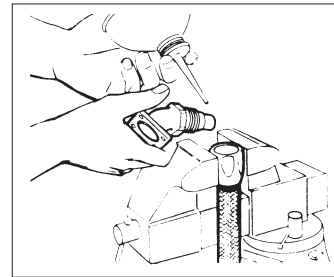

Step 5.
Complete assembly using wrench on elbow hex while continuing to hold hose in position. Tighten until hex is snug against socket. On forged elbow, use wrench on forging flats. Tighten until shoulder is snug against socket.

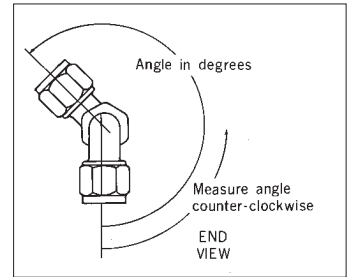

Step 6.
Adjustments may be necessary to obtain the desired position angle between two elbows. In order to minimize backing off elbows to position, the following procedure should supplement step 5:

- Tighten both elbows to within .031 inches of socket then start to position for relative angle between elbows.
- Finish assembly by adjusting both elbows. Backing-off to position should be avoided and in no case should exceed 1/4 turn. Maximum allowable gap between hex and socket is .031 inches.

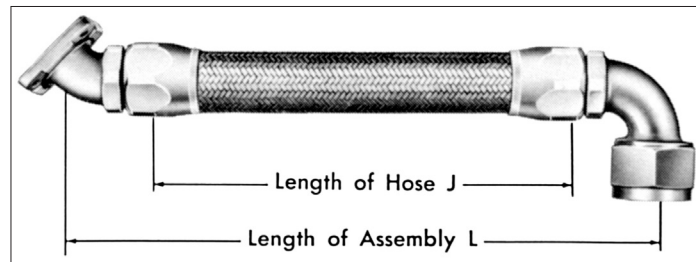

Step 3.
Lubricate inside of hose and nipple threads liberally. Use SAE30 lubricating oil. Avoid getting oil in the cutting spur of the nipple.

Step 7.
IMPORTANT – check for hose push-out. See step 6 above. Clean, inspect and proof test.

Note: Hose push-out after proof test should not exceed 1/32 inch on sizes 12 and up. None is allowable on smaller sizes.

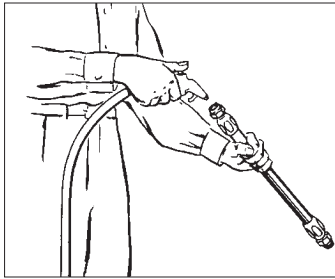

Clean

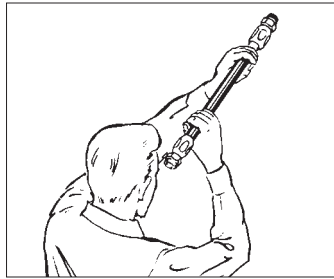

Inspect

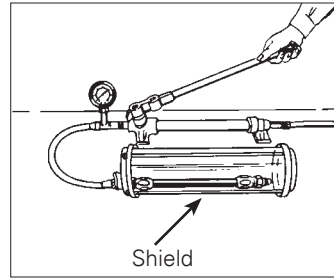

Proof Test/Fluid

Clean, Inspect, Proof Test

CLEAN...Clean hose after cutting to length. Be sure all cutting residue is dislodged. After assembly, clean each hose assembly internally using clean, dry compressed air.

INSPECT...Examine hose assembly internally for cut or bulged inner tube, obstructions and cleanliness. Examine Aeroquip hose assemblies with **"little gem"** fittings for hose push-out. Inspect for proper gap between nut and socket or hex and socket. Nuts should swivel freely.

PROOF TEST...Test hose assemblies in straight, horizontal position and observe for evidence of leakage while maintaining test pressure. Several hose assemblies may be tested at one time by connecting them in series.

1. LIQUID TEST MEDIUM... tighten cap only after all trapped air has bled from assembly. Use a heavy plastic protective cover when applying pressure.
2. Use proper proof-test fluid specified for hose:
3. Drain and cap.
4. Corrosion protection of fittings on hose assemblies.
 - a. Brass, corrosion resistant steel, and aluminum alloy fittings require no additional treatment.
 - b. Fittings on air or instrument hose assemblies should not be oiled. Dry thoroughly and cap with oil and grease-free caps.

Storage and Handling

1. BULK HOSE AND HOSE ASSEMBLIES...hose should be stored away from sunlight, heat, ozone, etc. To minimize obsolescence or deterioration of hose in storage, follow "first-in, first-out" principle in releasing stock for production or shipment.

2. Short hose lengths or assemblies may be conveniently stored in closed containers to protect from dust. Other hose assemblies should have the ends capped. Hose assemblies made up in the field should be marked with the date of assembly before being placed in storage.

NOTE: All hose assemblies taken from storage should be proof-tested prior to installation in aircraft.

| Type | Hose No. | Proof Test Fluid |
|---------------------------------|-----------|--------------------------------------|
| Pneumatic fuel, oil and coolant | 601/AE701 | Hydraulic oil (MIL-H-5606)* or water |

*Flush after proof-testing using oleum or other neutral spirits.

WARNING

FAILURE OR IMPROPER SELECTION, USE, OR ASSEMBLY OF THE PRODUCTS AND COMPONENTS FOR APPLICATIONS DESCRIBED HEREIN CAN RESULT IN POSSIBLE PROPERTY DAMAGE, PERSONAL INJURY OR DEATH.

This document and any other related information from Eaton® Aeroquip® or its affiliates and authorized distributors, provide product options for consideration by Users having

technical expertise with these products. Due to the wide variety of applications and operating conditions for these products and components, the User is solely responsible for making the final selection of the products and ensuring that all performance, safety and warning requirements for the User's intended application are met.

Eaton Aeroquip recommends that Eaton® Aeroquip® hose, fittings

or assembly equipment must be used only with other Eaton® Aeroquip® hose, fittings or assembly equipment, and Eaton Aeroquip and/or its affiliates disclaim any obligation or liability (including all incidental and consequential damages) to the extent Eaton® Aeroquip® hose, fittings or assembly equipment is used with any other manufacturer's hose, fittings or assembly equipment or in the event that Eaton Aeroquip recommended processes and

product instructions for hose assemblies are not followed.

The products described herein, including product features, specifications, designs, and availability are subject to change at any time without notice.

The Company retains the right to amend, change or modify any data in this document at any time.

Eaton
Aerospace Group
Fluid & Electrical Distribution Division
300 South East Avenue
Jackson, Michigan 49203-1972
Phone: (517) 787 8121
Fax: (517) 789 2947



Eaton
Aerospace Group
9650 Jeronimo Road
Irvine, California 92618
Phone: (949) 452 9500
Fax: (949) 452 9555
www.eaton.com/aerospace

Copyright © 2013 Eaton
All Rights Reserved
Copying or Editing is Forbidden
Form No. TF100-4E
April 2013