

# BEARINGS – GREASE FITTINGS

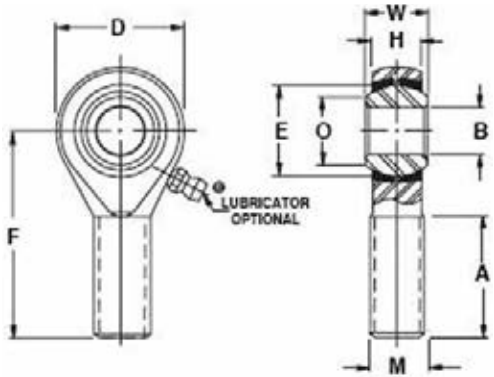

## ROD END MALE THREADED HMX EXTRA CAPACITY SERIES

### SPECIFICATIONS:

**Outer Member:** SAE 4130 steel heat treated to 175,000 PSI Cadmium Plated.

**Ball:** SAE 52100 Steel, Heat Treated, Chrome Plated.

**Inserts:** Aluminum Bronze

"L" in rod end number designates left hand thread.

Add letter 'M' to dash number for magnafluxed rod ends.

This series is equipped with lubricators as shown.

Add suffix "FG" to indicate flush type lubricator is required.

**Example:** HMX-4FG. Additional costs will apply.

**Note:** See Aurora Bearings page for equivalents to Heim HM & HF Series.



AP

Rod End Number	Equiv. Spherco Number	DIMENSIONS											Maximum Static Load in Lbs. approx		Approx. Weight in Lbs.	Price Ea.
		Bore	Ball Width	Housing Width	Ball Flat Dia.	Head Dia.	Length to Center of Ball	Over-All Length	Other Dimensions							
		B	W	H	O	D	F	G	A	N	M					
		+0.0015 -0.0005	+0.000 -0.005	+0.005 -0.005		+0.010 -0.010	+0.010 -0.010	+0.010 -0.010	Min.	Drill Dia.	Ball Dia.	Class 3A				
HMX-4G	ARE 4-20	.2500	.375	.281	.355	.750	1.560	1.937	1.000	#33	33/64	5/16"-24	3,260	1,710	.06	---
HMXL-4G	AREL-20									.113		UNF				---
HMX-5G	ARE- 5-20	.3125	.437	.344	.447	.875	1.375	2.312	1.250	#21	5/8	3/8"-24	4,920	2,376	.09	---
												UNF				---
HMX-6G	ARE 6-20	.3750	.500	.406	.517	1.000	1.375	2.438	1.250	#21	23/32	7/16"-20	7,240	2,946	.13	---
HMX-7G	ARE 7-20	.4375	.562	.437	.586	1.125	1.812	2.688	1.375	#21	13/16	1/2"-20	7,620	3,367	.18	---
HMXL-7G	AREL 7-20									.159		UNF				---
HMX-8G	ARE 8-20	.5000	.625	.500	.698	1.312	1.562	3.094	1.500	#3	15/16	5/8"-18	11,920	4,074	.30	---
HMXL-8G	AREL 8-20									.213		UNF				---

New Surplus HMX-8G ..... P/N 06-01661

## GREASE FITTINGS

Surface Check fittings of the MS15000 series have spring-loaded ball check in the tip. Conform to MIL-F-3541.



MS15001-1



MS15001-4



MS15003-5



AS15002-1P

MS Number	AS Number	Price	Surplus Number	Price	Thread	Shank L	Eff. Thread L	Overall L	Tip Angle
MS15001-1	AS15001-1P	---	04-02325	---	1/4-28 Tapered	3/16"	.109	1/2"	0°
MS15001-2	AS15001-2P	---	04-02326	---	1/4-28 Tapered	5/8"	.20	31/32"	0°
MS15001-3	AS15001-3P	---	04-02327	---	1/4-28 Tapered	13/64"	.11	13/16"	45°
MS15001-4	AS15001-4P	---	04-02313	---	1/4-28 Tapered	3/16"	.109	1/2"	90°
MS15002-1	AS15002-1P	---	04-02328	---	1/4-28 Tapered	5/32"	.07	33/64"	0°
MS15002-3	AS15002-3P	---	04-02329	---	1/4-28 Tapered	1/8"	.07	39/64"	45°
MS15003-1	AS15003-1P	---	04-02330	---	1/8 NPT	19/64"	.19	11/16"	0°
MS15003-2	AS15003-2P	---	04-02331	---	1/8 NPT	25/32"	.19	1-1/4"	0°
MS15003-3	AS15003-3P	---	04-02332	---	1/8 NPT	19/64"	.19	29/32"	30°
MS15003-4	AS15003-4P	---	04-02333	---	1/8 NPT	19/64"	.19	57/642"	45°
MS15003-5	AS15003-5P	---	04-02315	---	1/8 NPT	9/32"	.188	31/32"	65°
MS15003-6	AS15003-6P	---	04-02314	---	1/8 NPT	9/32"	.188	15/16"	90°